

SPECIFICATIONS	
CONTACT CARRIER MATERIAL (J1)	TPU or NYLON
MOLDED MATERIAL/COLOR (J1)	TPU/BLUE-GRAY
CONTACT CARRIER MATERIAL/COLOR (CBC5)	NYLON/BLACK
MOLDED HEAD MATERIAL/COLOR (CBC5)	TPU/BLACK
HOUSING MATERIAL/PLATING (J1)	BRASS/NICKEL
CONTACT MATERIAL/PLATING (J1)	BRASS/GOLD
RATED CURRENT [A]	4.0 A
RATED VOLTAGE [V]	250 V
CABLE JACKET/COLOR	PVC/GREY
CONDUCTOR INSULATION MATERIAL	PE (DATA), PVC (POWER)
NUMBER OF CONDUCTORS [AWG]	4x22 AWG, 22 AWG DRAIN
SHIELDING	FOIL (PAIRS), FOIL (OVERALL)
TEMPERATURE RATING	-40°C to +80°C (-40°F to +176°F)
PROTECTION CLASS	MEETS NEMA 1,3,4,6P AND IEC IP68 (IP20: CBC5)

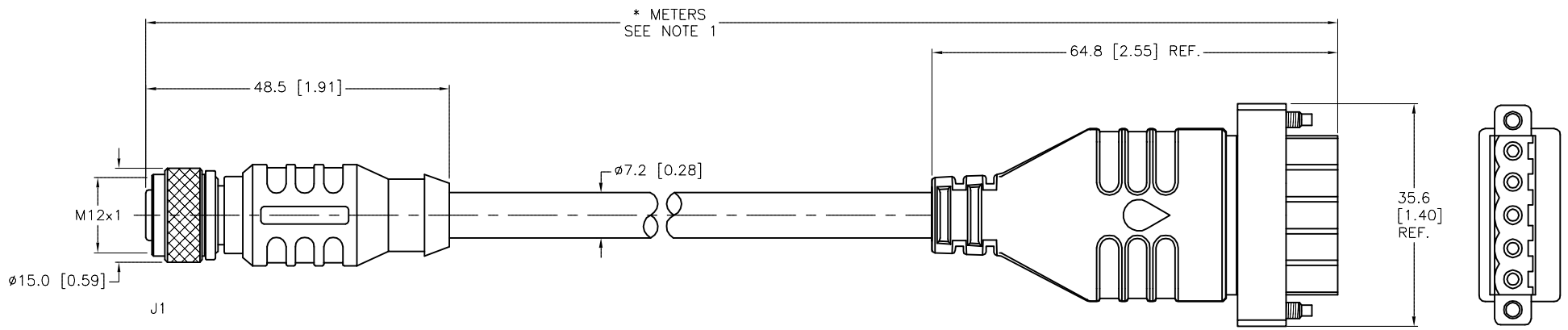

CABLE LENGTH	TOLERANCE*
ALL LENGTHS	+ 4% (OR 50mm) OF LENGTH - 0% (OR 0mm) OF LENGTH WHICHEVER IS GREATER
STRIP LENGTH	TOLERANCE*
0-7mm	±0.5mm
8-29mm	±1.0mm
30-49mm	±2.0mm
50-69mm	±3.0mm
70-100mm	±4.0mm
OVER 100mm	±5.0mm

* UNLESS OTHERWISE SPECIFIED

NOTES:
 1. "*" INDICATES CABLE LENGTH IN METERS. CONTACT TURCK TO ORDER SPECIFIC LENGTHS.

SOURCE DRAWING - FOR REFERENCE ONLY

RELATED DOCUMENTS	3RD ANGLE PROJECTION	THIS DRAWING IS CONFIDENTIAL AND THE PROPERTY OF TURCK INC. USE OF THIS DOCUMENT WITHOUT WRITTEN PERMISSION IS PROHIBITED.	TURCK 3000 CAMPUS DRIVE MINNEAPOLIS, MN 55441 1-800-544-7769 (763) 553-7300 (763) 553-0708 fax www.turck.us	
1.		DRFT RDS	DATE 10/24/05	DESCRIPTION RKC CBC5 572-*M
2.		APVD	SCALE 1=1.0	
3.	ALL DIMENSIONS DISPLAYED ON THIS DRAWING ARE FOR REFERENCE ONLY	UNIT OF MEASUREMENT MILLIMETER [INCH]		IDENTIFICATION NO.
4.		CONTACT TURCK FOR MORE INFORMATION	DO NOT SCALE THIS DRAWING	REV D
MATERIAL				FILE: 777007533
FINISH				SHEET 1 OF 1

D	DRAWING PROCESSED AS PART OF ECO 33971	CBM	04/06/11	33971
REV	DESCRIPTION	BY	DATE	ECO NO.